

# 3K-25K

## Quick Installation

### Installation and Operation Manual



## 1. Instructions

The inverter has been constructed according to the applicable safety and technical guidelines.

Use the inverter in installations that meet the following specifications ONLY:

1. Permanent installation is required.
2. The electrical installation must meet all the applicable regulations and standards.
3. The inverter must be installed according to the instructions stated in this manual.
4. The inverter must be installed according to the correct technical specifications.
5. To startup the inverter, the Grid Supply Main Switch (AC) must be switched on, before the solar panel's DC isolator shall be switched on. To stop the inverter, the Grid Supply Main Switch (AC) must be switched off before the solar panel's DC isolator shall be switched off.

## 2. Mounting the Inverter

Dimensions of wall bracket:

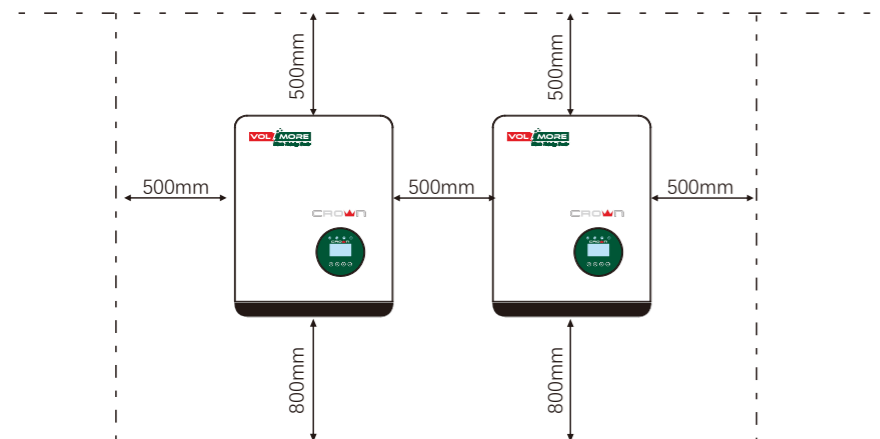

▲ Figure 2.0 Inverter Mounting clearance

Please see Figure 2.2 and Figure 2.3 for instruction on mounting the inverter.

The inverter shall be mounted vertically. The steps to mount the inverter are listed below:  
 1. According to Figure 2.0, select the bracket mounting height and mark the mounting hole. After marking, punch the hole according to the mark. For brick wall drilling, expansion bolts shall be suitable for fixing.

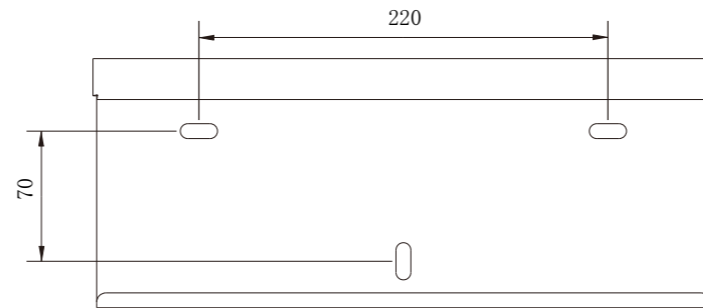

▲ Figure 2.1 Inverter wall mounting

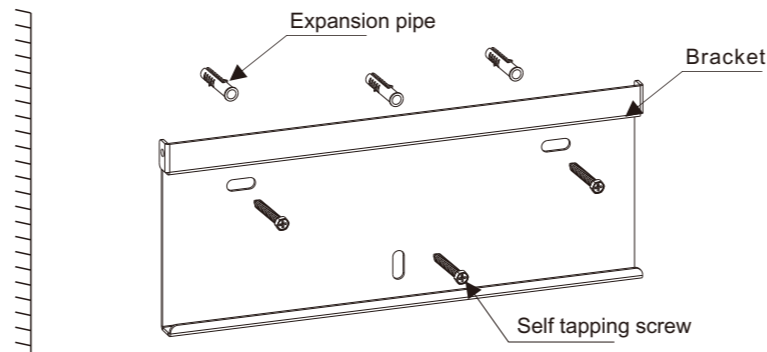

▲ Figure 2.2 Inverter wall mounting

2. Make sure that the bracket is horizontal and the mounting hole (as shown in Figure 2.2) is correctly marked, and drive the expansion pipe into the wall with a hammer.
3. Use the suitable screws to fix the bracket to the wall.



### WARNING:

The inverter must be mounted vertically. If it is necessary to install a canopy, it is necessary to install the canopy first and then fix the inverter to avoid the blocking of the fan caused by the cement debris falling during drilling.

4. Lift up the inverter (be careful to avoid body strain), and align the back bracket on the inverter with the convex section of the mounting bracket. Hang the inverter on the mounting bracket and make sure the inverter is secure (see Figure 2.3).

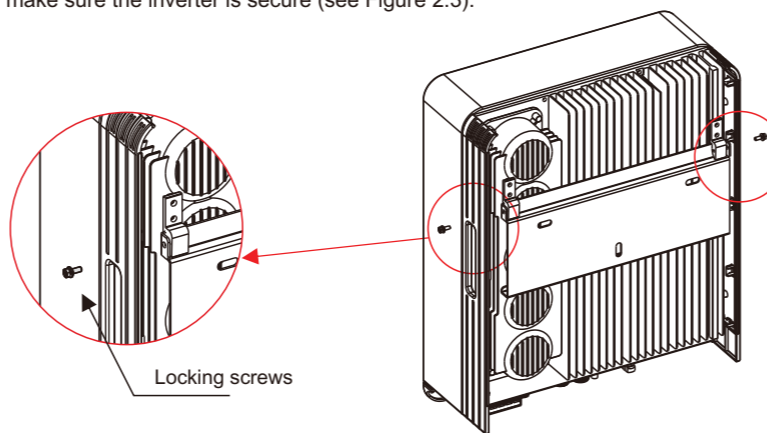

▲ Figure 2.3 Wall Mount Bracket

5. Use M4 screws in accessory to lock the inverter to the mount bracket.

## 3. Electrical Connections

### 3.1 Connect PV side of inverter

The electrical connection of the inverter must follow the steps listed below:

1. Switch the Grid Supply Main Switch (AC) OFF.
2. Switch the DC Isolator OFF.
3. Assemble PV input connector to the Inverter.



Check whether the polarity of the connecting cable of the photovoltaic string is correct, and ensure that the open circuit voltage under any condition does not exceed the upper limit of the inverter input value of 1100V.



Please don't connect PV array positive or negative pole to the ground, it could cause serious damages to the inverter



Before connection, please make sure the polarity of the output voltage of PV array matches the "PV+" and "PV-" symbols.

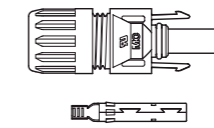

▲ Figure 3.1 PV+ Connector

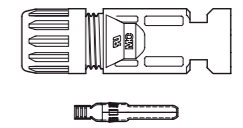

▲ Figure 3.2 PV- Connector

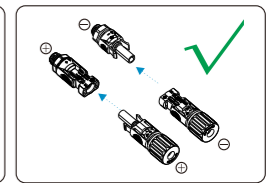
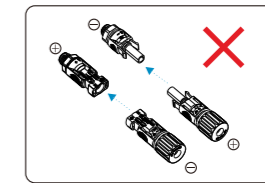

Check the positive and negative polarity of the PV strings, and connect the PV connectors to the right terminals. Serious damages to the inverter and connector over temperature may occur.



Please use approved DC cable for PV system.

Cable type	Cross section(mm <sup>2</sup> )	
	Range	Recommended value
Industry generic PV cable	4.0-6.0 (12-10AWG)	4.0 (12AWG)

The steps to assemble the DC connectors are listed as follows:

1. Strip off the DC wire for about 7mm, Disassemble the connector cap nut.

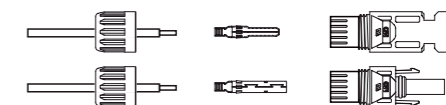

2. Insert the wire into the connector cap nut and contact pin.

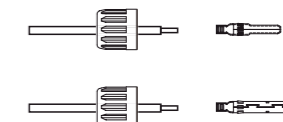

3. Crimp the contact pin to the wire using a proper wire crimper.

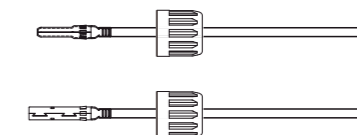

4. Insert the contact pin to the top part of the connector and screw up the cap nut to the top part of the connector.



5. Then connect the DC connectors to the inverter. Small click will confirm connection.

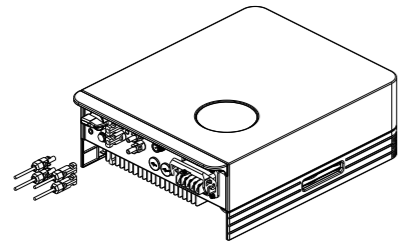

#### 4. Connection of AC output

For all AC connections, 4-10mm<sup>2</sup> 105 XJ cable is required to be used. Please make sure the resistance of cable is lower than 1 ohm. If the wire is longer than 20m, it's recommended to use 10mm<sup>2</sup> cable.

**WARNING:**



There are "L1,L2,L3" "N" "PE" symbols marked inside the connector, the Line wire of grid must be connected to "L1,L2,L3" terminal; the Neutral wire of grid must be connected to "N" terminal; the Earth of grid must be connected to "PE"

Object	Description	Value
A	External diameter	10mm
B	Copper conductor cross-section	4mm <sup>2</sup>

Model	Cross section Range	Remark
3-12K	4-6mm <sup>2</sup>	
15-25K	8-16mm <sup>2</sup>	

Connect grid side of inverter

1. First check the AC circuit breaker and disconnect the inverter and the grid.
2. Use wire stripper to peel the outer surface of the cable for about 50 mm, and then peel off the wire skin of 5 wires, as shown in the figure below;

Step 1. Strip the protection layer and insulation layer by specific length, as described in the figure below.

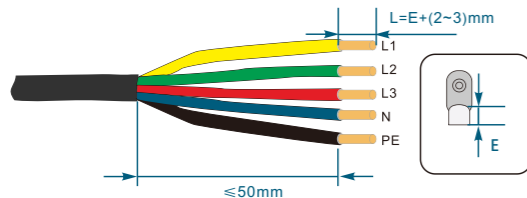

Step 2. Make the cable and crimp the OT terminal.

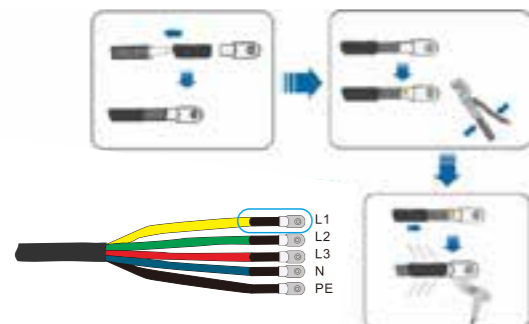

Step 3. Follow the instruction and secure the cable to corresponding terminals.

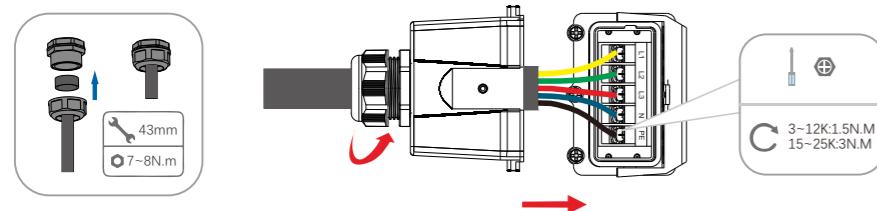

Step 4. Secure the junction box, fasten the buckle, and secure it with screw.

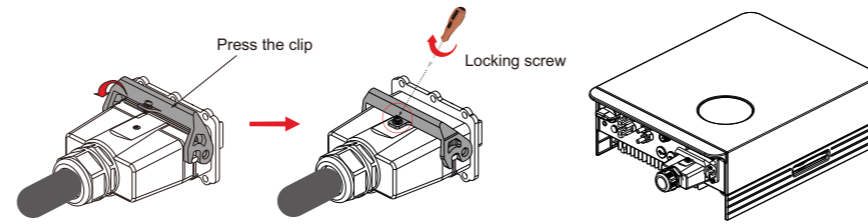

▲ Figure 4.1 Connect the AC Connector to the Inverter

#### 5. External ground connection

An external ground connection is provided at the right side of inverter.

Prepare of terminal: M4, tighten the screw. The machine comes with it.

Use appropriate tools to screw out the screw and crimp the lug to the terminal.

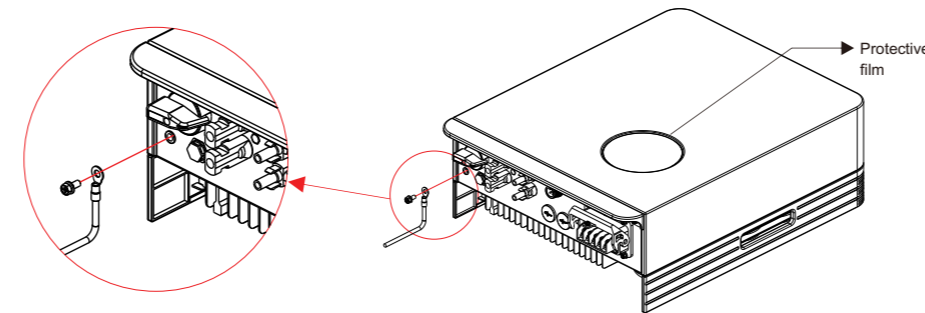

**NOTE:**

After the installation and detection of inverter, the protective film on LCD surface needs to be removed to avoid the influence of weathering.

#### 6. Inverter monitoring connection

The inverter can be monitored via Wi-Fi or GPRS. All communication devices are optional (Figure 6.1). For connection instructions, please refer to the Monitoring Device installation manuals.

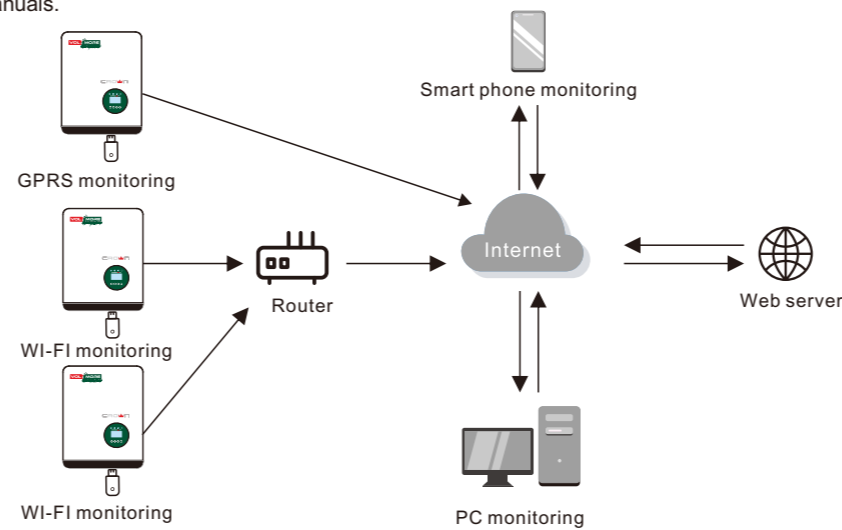

▲ Figure 6.1 Communication function

The inverter is equipped with standard RS485 and WLAN/GPRS communication ports, and the RS485 communication port is mainly used for the software upgrade, WLAN/GPRS communication port is for inverter wireless monitoring.

Pin	Description	Pin	Description
1	VCC	3	485A
2	GND	4	485B

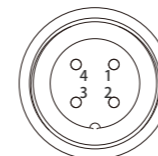

#### 7. CT connections(optional)

This inverter has integrated export limitation functionality. To use this function, a CT must be installed, if use the CT, please reference below picture. The CT should be fitted around the live conductor on the grid side of the main incoming consumer unit. Use the directional flow indication arrow on the CT to ensure it is fitted in the correct orientation. The arrow should be pointing towards the inverter, not the grid.

Pin	Description
1	NC
2	NC
3	485A positive electrode
4	485B negative pole

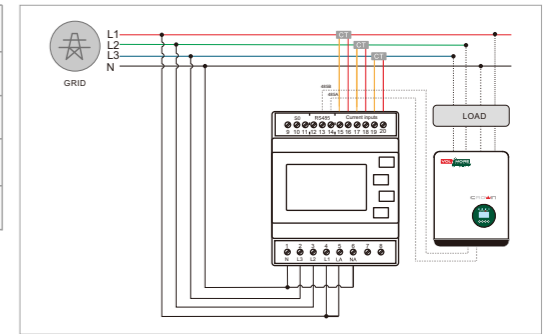

Please follow below figure to assemble CT connector.

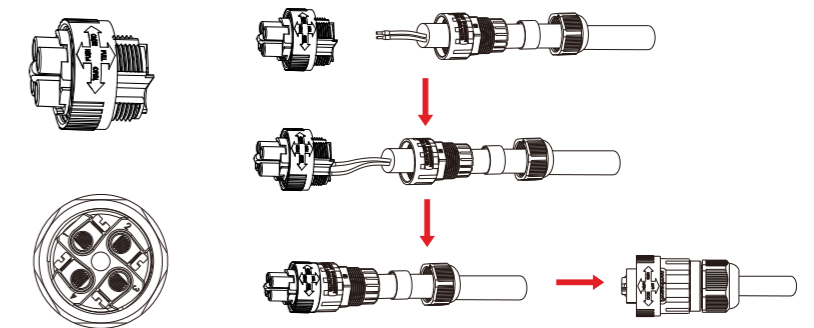

▲ Figure 7.1 CT connector

#### 8. DRED port connections(optional)

DRED means demand response enable device. The AS/NZS 4777.2:2015 required inverter need to support demand response mode(DRM). This function is for inverter that comply with AS/NZS 4777.2:2015 standard. Inverter is fully comply with all DRM. A 6P terminal is used for DRM connection.

Pin	Description	Default value
PIN1-PIN6	Shutdown	Shutdown
PIN2-PIN6	Power limitation 0%	Power limitation 0%
PIN3-PIN6	Power limitation 50%	Power limitation 50%
PIN4-PIN6	Power limitation 75%	Power limitation 75%
PIN5-PIN6	Power recovery 1%/4s	Power recovery 1%/4s

Please follow below figure to assemble DRM connector.

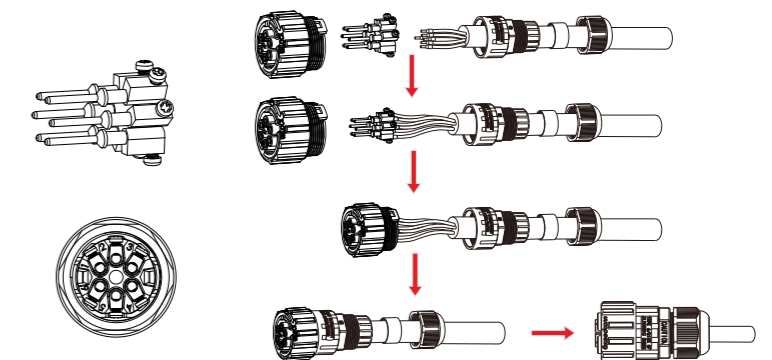

▲ Figure 8.1 DRM connector

\* Registered accounts and passwords can be logged in at the same time on the APP and website, or on multiple devices. This manual is a quick user manual. Users can contact our technical support if they don't know the specific operation.